

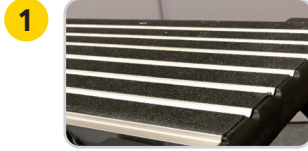

# DELTA STEP

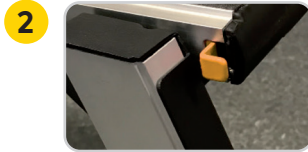

**PLATEAU ANTIDÉRAPANT**  
1 mètre avec bandes antidérapantes



**PRATIQUE !**  
Bouton de verrouillage automatique.

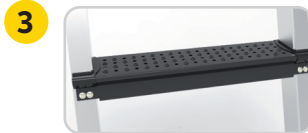

**CONFORTABLE !**  
Marches en acier perforées antidérapantes.



**CROCHET DE VERROUILLAGE**



**POIGNÉE DE TRANSPORT FACILE**



**STABLE**  
patins antidérapants.

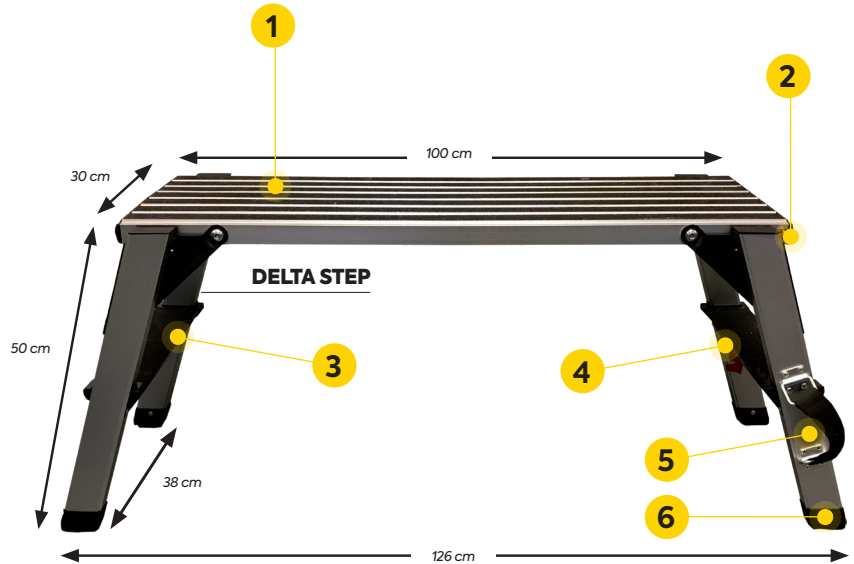

- ✓ Garantie 2 ans
- ✓ Charge maxi : 150 Kg



**LIVRÉ EN BOÎTE CARTON  
IMPRIMÉE ET TRANSPORTABLE**

## NOTICE D'UTILISATION



<b>Code Article</b>					<b>Produit replié</b>		
451700	3172964517003	(1)	(m)	(m)	(L x l x h) (m)	(L x l x P) (m)	(kg)
		2.50	1.00	0.50	0.96 x 0.20 x 0.39	0.20 x 0.40 x 1.01	8.00

(1) Hauteur d'accès maxi donnée à titre indicatif. - Hauteur d'accès maxi = Votre taille les bras levés + La hauteur du plateau.